

COVERT CAMERA

THC-512S2S

600TVL/D-WDR SMOKE DETECTOR CAMERA



- FEATURES -

- 1/3" SONY High-Resolution Super HAD II CCD
- 600TV Lines Horizontal Resolution
- Excellent Low Light Sensitivity of 0.3Lux/F1.2
- Day & Night
- Digital WDR : Digital Wide Dynamic Range
- DNR : Digital Noise Reduction
- HLC : High Light Compensation
- Blemish Compensation : 64 Points
- Lens Shading
- Parking Line
- RS-485 Communication (Pelco-D/P)
- Built-in OSD Controller
- Board Lens f=3.6mm



1/3" SONY
SUPER HAD II CCD



DAY & NIGHT



DIGITAL
WDR
DIGITAL WIDE
DYNAMIC RANGE



2D+3D
DNR
2D+3D DIGITAL
NOISE REDUCTION



HLC
HIGH-LIGHT
COMPENSATION



AUTO IRIS



DC 12V

- DIMENSION -

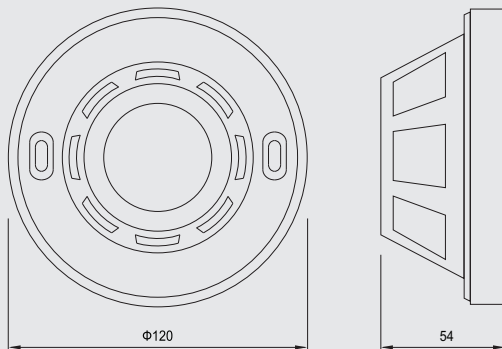

- SPECIFICATIONS -

| THC-512S2S | | |
|------------------------|---|----------------------------|
| Signal Format | NTSC | PAL |
| Horizontal Resolution | 600TV Lines | |
| Image Sensor | 1/3" SONY High-Resolution Super HAD II CCD | |
| Total Pixels | 811(H) x 508(V) | 795(H) x 596(V) |
| Effective Pixels | 768(H) x 494(V) | 752(H) x 582(V) |
| Scanning System | 2:1 Interlace | |
| Synchronization | Internal | |
| Scanning Frequency | 15.734 KHz(H), 59.94 Hz(V) | 15.625 KHz(H), 50.00 Hz(V) |
| Video Output | CVBS : 1.0Vp-p/75Ω | |
| Min. Illumination | 0.3Lux/F1.2 | |
| Electronic Shutter | 1/60 ~ 1/100,000 sec | 1/50 ~ 1/100,000 sec |
| Iris Control | MANUAL | |
| Signal to Noise Ratio | 52dB (AGC Off, Weight : On) | |
| Backlight Compensation | BLC / HLC / OFF | |
| White Balance | ATW1 (2,300°K ~ 9,500°K) / ATW2 (2,000°K ~ 11,000°K) / MANUAL | |
| Gain Control | LOW / HIGH / OFF | |
| 2D+3D DNR | ON / OFF (Level Adjustable) | |
| Day & Night | AUTO / COLOR / BW / EXT | |
| Digital WDR | ON / OFF | |
| Motion Detection | ON / OFF (4 Zone) | |
| Privacy | ON / OFF (8 Zone) | |
| Horizontal Mirror | ON / OFF | |
| Communication | Protocol : Pelco D/P, Cam ID 255, 2400 ~ 57600 | |
| Lens Shading | ON / OFF | |
| Parking Line | User Setting (LT, LB, RT, RB, F, N, T) | |
| OSD | Built-in (English, Chinese) | |
| Lens | Board Lens f=3.6mm | |
| Input Voltage | DC 12V (±10%) | |
| Power Consumption | Max. 1.5W | |
| Operating Temp/Hum | Temperature : -10°C ~ +50°C / Humidity : 30% ~ 80% RH | |
| Storage Temp/Hum | Temperature : -10°C ~ +50°C / Humidity : 30% ~ 80% RH | |
| Dimension | 120(Ø) x 54(H)mm | |
| Weight | Approx. 80g | |